

N1076B/7A/7B/8A DCA-M

Optical and electric clock data recovery solutions

Introduction

For optical and electrical waveform analysis, the N1076B electrical clock recovery up to 64 GBd, the N1077A optical/electrical clock recovery up to 32 GBd, the N1077B optical/electrical clock recovery up to 64 GBd, and the N1078A optical/electrical clock recovery up to 64 GBd provide clock recovery solutions.

The N107x-series user interface and operating system is identical to the modern FlexDCA interface of the N1000A and 86100D. A user-provided PC running N1010A FlexDCA software controls the N107X over a simple USB 2.0 or 3.0 connection.



Table of Contents

Introduction	1
Electrical and Optical Clock Recovery Solutions	3
What Does Clock Recovery Do?	5
Why Use Clock Recovery?	6
Electrical Clock Recovery	7
Optical/Electrical Clock Recovery	9
Characterize Next-generation Receivers and Transmitters	13
Application Example	16
N1076B Specifications	18
N1077A Specifications	21
N1077B Specifications	25
N1078A Specifications	32
Ordering Information	40
Accessories	43
Confidently Covered by Keysight Services	44
Recommended services	45

Electrical and Optical Clock Recovery Solutions

Keysight clock recovery solutions offer a wide data rate range and are ideal for many transmitter and receiver test setups for computers, datacom, and communication standards. The Keysight Technologies, Inc. electrical clock recovery solutions provide clock recovery capabilities for electrical non-return-to-zero (NRZ) and pulse amplitude modulation 4-level (PAM4) signals.



- Supports NRZ and PAM4 signals
- Integrated O/E and clock recovery design
- Optical splitter: Integrated or External - user supplied
- Ultra-low residual random jitter < 100 fs RM
- Jitter spectrum analysis (JSA) capability
- Golden phase-locked loop (PLL) for compliant operation

The Keysight Technologies, Inc. optical/electrical clock recovery integrates electrical clock recovery with an amplified optical-to-electrical (O/E) converter, enabling it to work for both electrical and optical applications. Optional integrated optical splitters are available, which simplifies setup and improves ease-of-use.

All models include adjustable loop bandwidth and selectable peaking, and provide high sensitivity and low intrinsic jitter performance that ensures optimal measurement accuracy. The optional jitter spectrum analysis (JSA) capability provides insight into the magnitude and distribution of low-frequency jitter, which is helpful in troubleshooting root cause for excessive jitter.

Recover clocks from closed eyes: The N1076B, N1077B, and N1078A electrical clock recovery includes integrated variable equalizers on both electrical inputs to enable opening closed eyes.

PLL and jitter spectrum analysis

Use the Keysight Technologies FlexPLL analysis software (N1010300A Signal Integrity Package) to make fast, accurate, and repeatable measurements of phase-locked loop (PLL) bandwidth/jitter transfer. The N107x can be configured as a jitter receiver, which can be combined with a precision jitter source, such as the Keysight Technologies M8000 Series of BER test solutions, to create a PLL stimulus-response test system. PCI Express®-approved PLL bandwidth compliance tests are pre-configured, with automatic report generation.

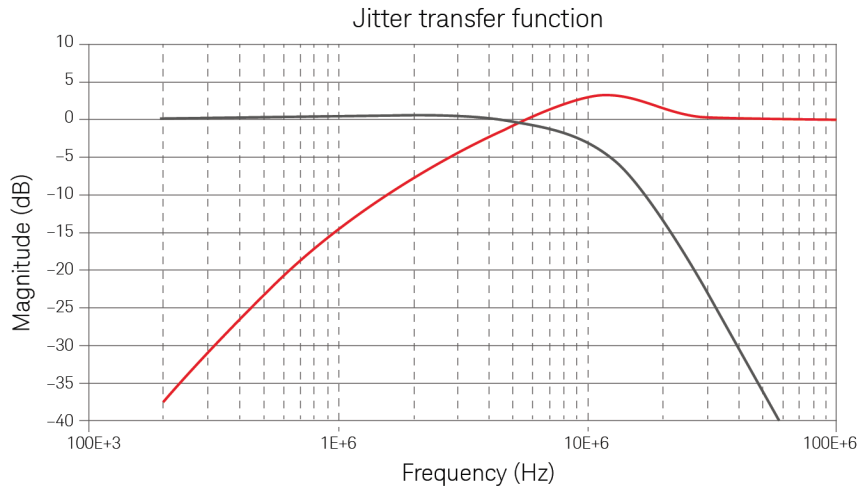

Figure 1. The N107x clock recovery may be configured as a jitter receiver when characterizing phase-locked loop (PLL) designs using FlexPLL analysis software.

What Does Clock Recovery Do?

Clock recovery takes an incoming data (or clock) signal, locks onto it using a phase-locked loop (PLL) circuit, and outputs a recovered clock. The recovered clock can be used as a timing reference for oscilloscopes or BERTs.

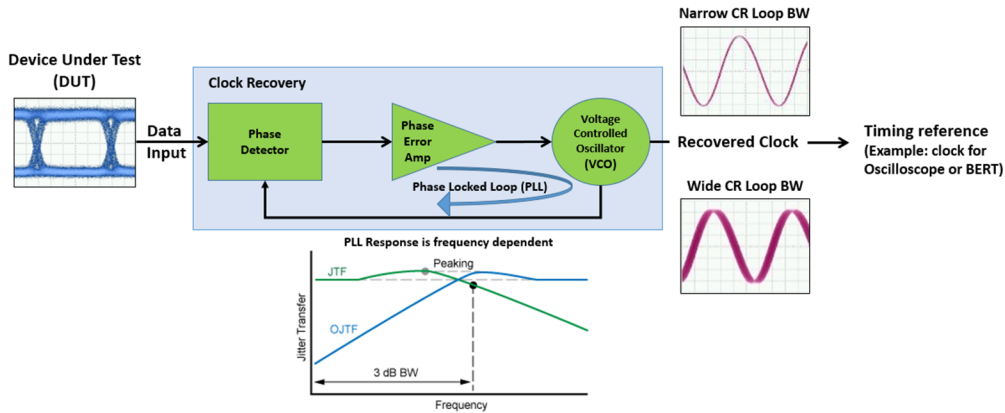

Figure 2. Clock recovery can be used to extract a timing reference signal from an incoming data signal. The amount of jitter on the recovered clock is determined by the loop bandwidth of the PLL.

Standards typically specify loop order, bandwidth, and peaking, all of which determines how much jitter on the incoming signal will appear on the recovered clock (also known as the jitter transfer function, or JTF). Users can configure the FlexDCA graphical user interface (GUI) to adjust these parameters and ensure standards-compliant clock recovery (often referred to as a “golden PLL”).

Why Use Clock Recovery?

Standards compliance

To comply with standards such as IEEE 802.3 Ethernet, Fibre Channel, or the Optical Interworking Forum – Common Electrical Interface (OIF-CEI), clock recovery must be used when performing measurements such as jitter, eye width, and/or eye height.

Clock-less devices

Another reason to use clock recovery is when a clock or trigger signal is not provided by the device under test (DUT), but a clock is required to trigger an oscilloscope, or the error detector in a BERT.

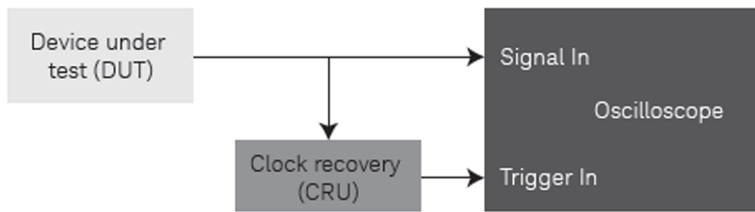

Figure 3. Clock recovery provides a compliant trigger signal for use by an oscilloscope or BERT.

Electrical Clock Recovery

The N1076B provides instrument-grade clock recovery on electrical signals up to 64 Gb/s. Adjustable loop bandwidth and peaking ensures standards-compliant clock recovery capability. The N1076B is controlled via a USB connection to an N1000A or 86100D DCA-X mainframe or to a standalone PC running N1010A FlexDCA software.

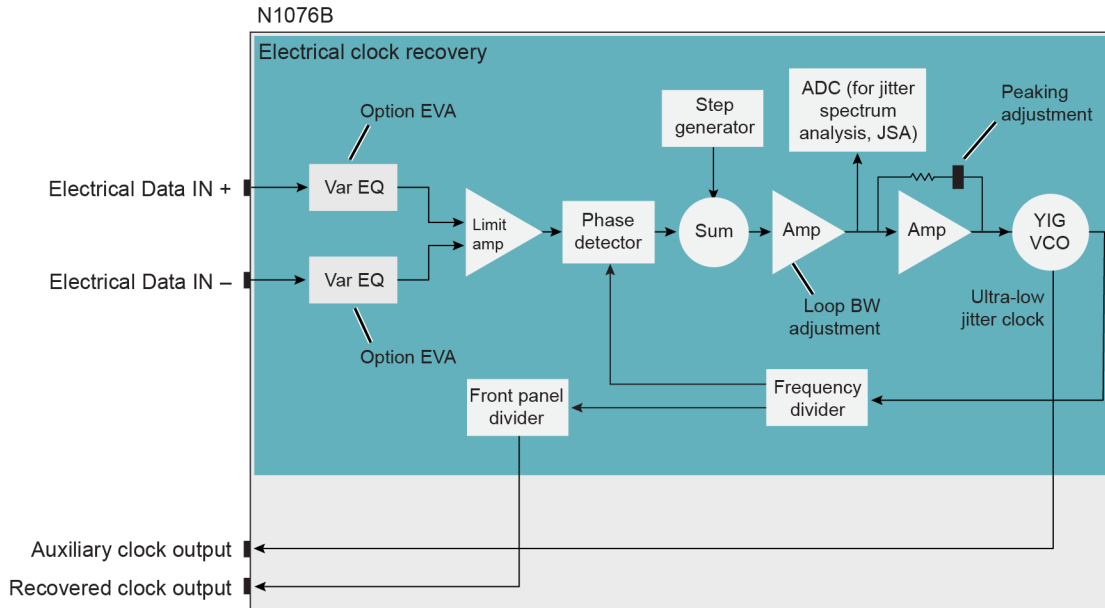

Figure 4. As shown in this block diagram, the N1076B recovers clock signals from NRZ and PAM4 input signals, and provide jitter analysis capability (Option JSA) for additional insight and measurement accuracy.

Accurate clock recovery for high-speed applications:

- Recovers clock from data streams up to 64 GBd (N1076B Option 264)
- Supports both NRZ and PAM4 signal types
- Tolerates small input signals
- Provides an auxiliary clock output signal with intrinsic random jitter as low as 100 fs RMS for accurate measurements. Use to connect to N1000A DCA-X precision timebase (PTB) input
- Optional jitter spectrum analysis (Option JSA) feature provides additional insight into jitter and allows users to perform jitter measurements using an “ideal” clock recovery model
- Connects to an N1000A DCA-X or PC via a USB 2.0 interfaceLoop

Optical/Electrical Clock Recovery

The N1077A, N1077B, and N1078A provide instrument-grade clock recovery with adjustable loop bandwidth and peaking on both electrical and optical signals up to 64 GBd. All are controlled via a USB connection to an N1000A or 86100D DCA-X mainframe or to a standalone PC running N1010A FlexDCA software.



The N1077A supports both multimode and single-mode operation, can be ordered with integrated 70-30 multimode and 50-50 single-mode splitters (option SMS) as shown in [Figure 5](#) or with no splitter (option SXT) as shown in [Figure 8](#) and operates up to 32.8 GBd.



The N1077B supports multimode and single-mode operations and can be ordered with an integrated 70-30 splitter (option SMM) as shown in [Figure 6](#) or with no splitter (option SXT) as shown in [Figure 8](#) and operates up to 64 GBd.



The N1078A supports single-mode operation only and can be ordered with an integrated 50-50 single-mode splitter (option S50) as shown in [Figure 7](#) or with no splitter (option SXT) as shown in [Figure 8](#) and operates up to 64 GBd.

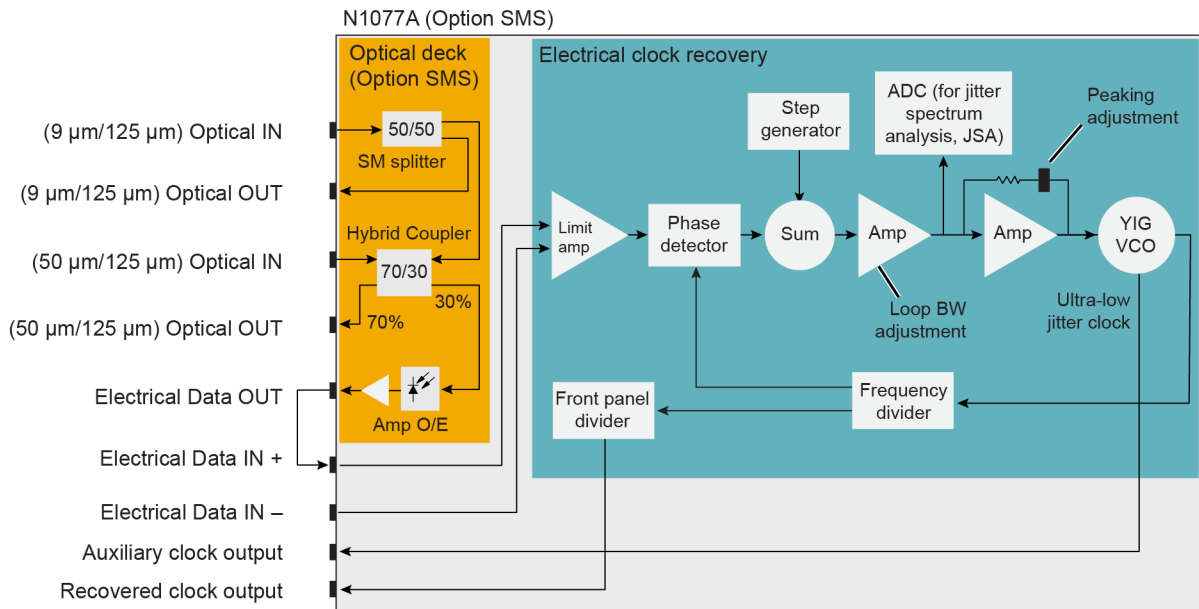

Figure 5. The N1077A with Option SMS combines an integrated optical deck (a splitter, bulk-optics coupler, and an amplified O/E) with an instrument grade electrical clock recovery circuit.

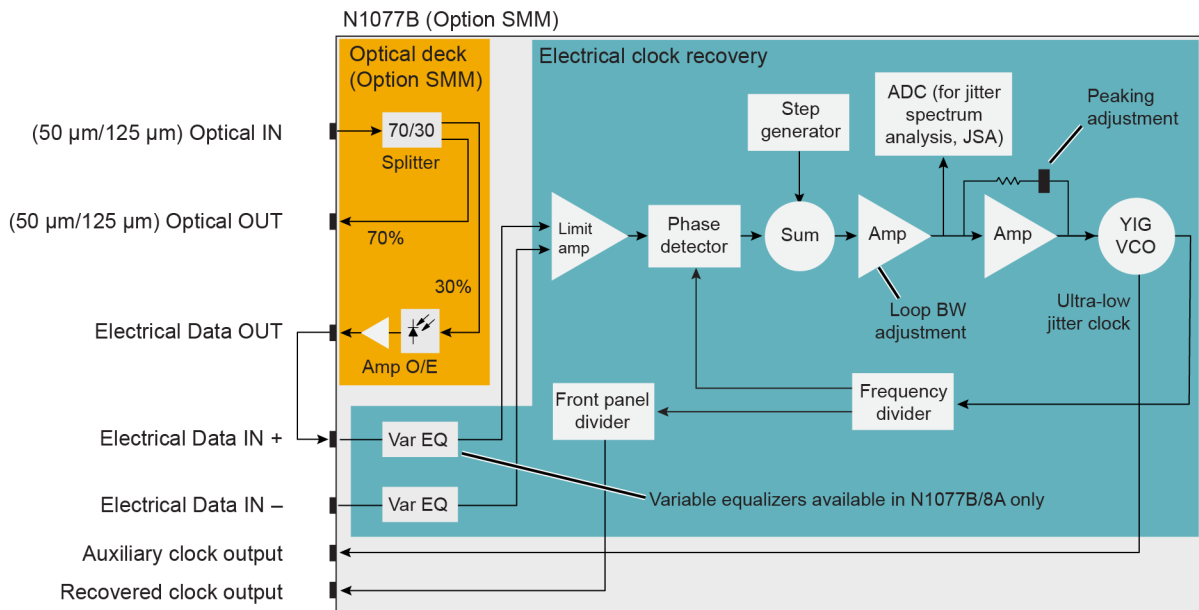

Figure 6. The N1077B with Option SMM combines an integrated 70-30 splitter and an amplified O/E with an instrument grade clock recovery circuit.

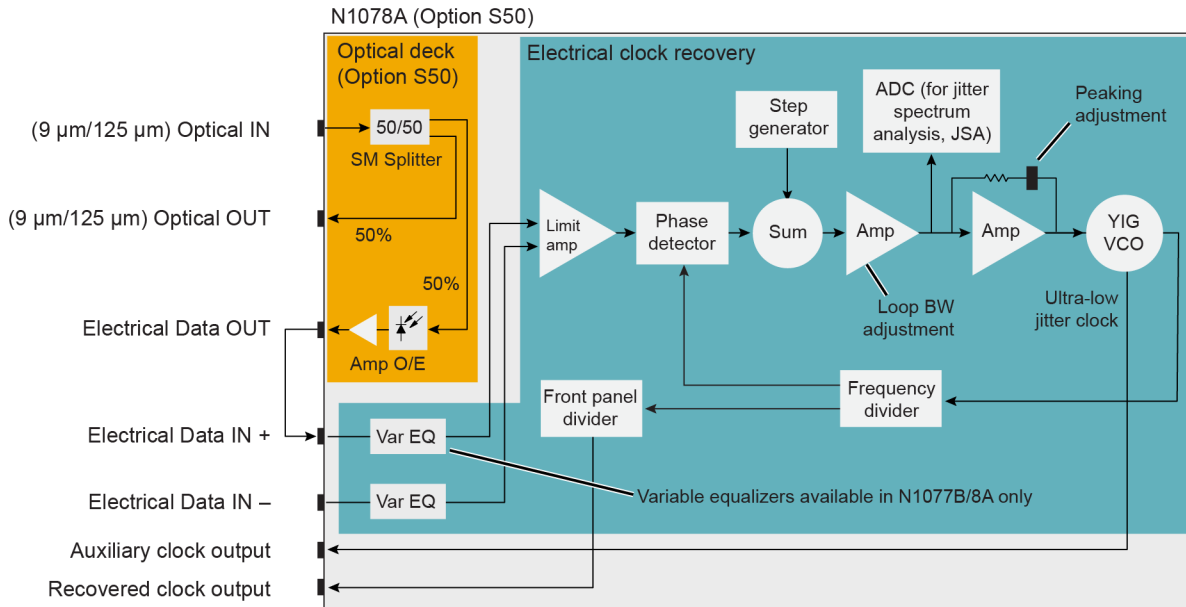

Figure 7. The N1078A with Option S50 combines an integrated 50-50 splitter and an amplified O/E with an instrument grade clock recovery circuit.

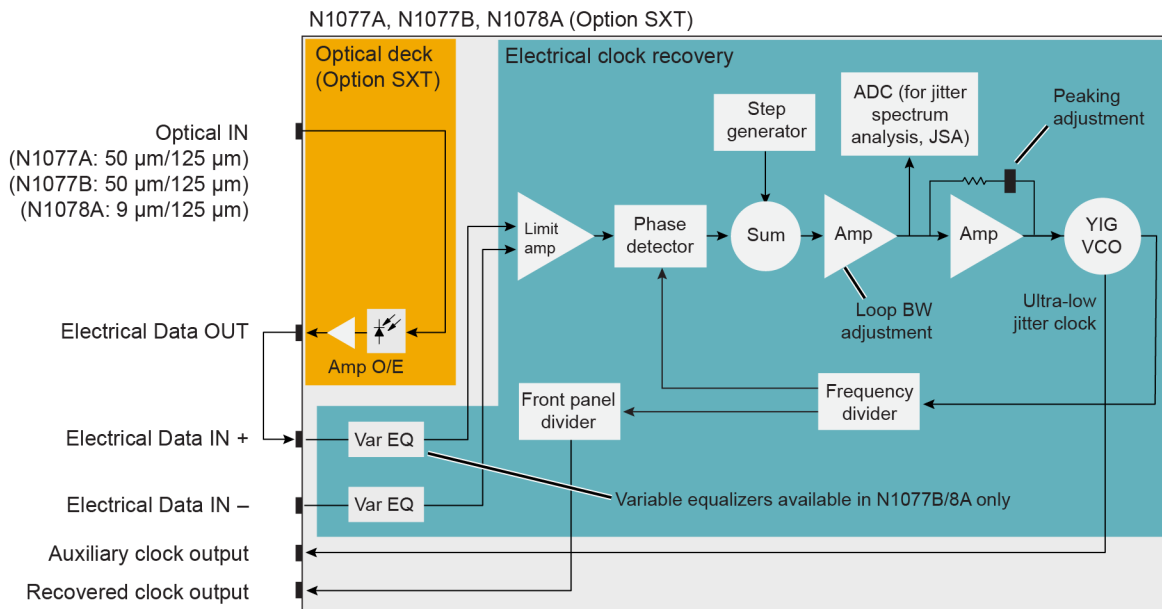

Figure 8. The N1077A, N1077B, and N1078A with Option SXT combine an integrated amplified O/E with an instrument grade electrical clock recovery circuit. The user supplies an external optical splitter as necessary (10-90, 20-80, 30-70, 50-50, etc.).

Accurate, convenient solution for recovering clock signals from high-speed optical communication signals:

- Optional integrated splitter/coupler extracts a portion of the optical test signal using a built-in coupler. Main optical signal is returned to the front panel. Converts the tapped optical signal to an electrical signal using an amplified O/E for greater sensitivity
- Recovers clock from data streams up to 64 GBd N1077B and N1078A (option 264)
- Supports both NRZ and PAM4 signal types
- Provides an easy method for using the electrical clock recovery solution with optical signals

Characterize Next-generation Receivers and Transmitters

The wide data-rate range of Keysight's clock recovery solutions allows testing of standards like 100/400G Ethernet and 64 GFC, while covering existing lower speed standards.

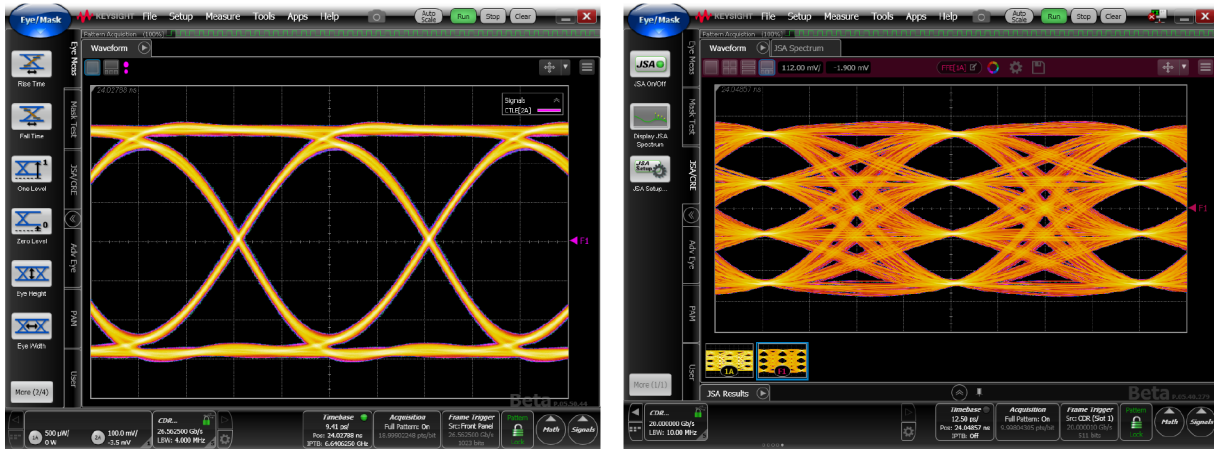

Figure 9. The N107x provides clock recovery capabilities for NRZ (left) and PAM4 (right) signals.

Recover clocks or clean-up clocks

The N107x provides clock signals for BERTs or oscilloscopes when access to appropriate clock signals from the DUT is not possible. It can also act as a clean-up PLL for existing clocks with excessive intrinsic jitter to allow accurate measurements.

Measure the real performance of clock-less devices

Accurate transmitter measurements are possible because of low intrinsic jitter, paired with tunable loop bandwidth, selectable peaking, and good sensitivity. The N107x's auxiliary clock output provides ultra-low intrinsic random jitter of less than 100 fs RMS, making it the ideal companion for sampling scopes equipped with a precision time base.

Perform more accurate jitter measurements and gain greater insight into the root cause(s) of jitter

Jitter spectrum analysis (Option JSA) integrates a step generator and a low-noise, 14-bit ADC into the clock recovery design (see [Figure 5](#), [Figure 6](#), [Figure 7](#), and [Figure 8](#)). The step generator and ADC characterize the clock recovery PLL in real-time, providing FlexDCA with the information that is necessary to calculate jitter at the input to the instrument.

JSA uses this information to:

- Optimize the accuracy of random jitter measurements performed by Jitter mode (N1010100A R&D Package)
- Emulate an “ideal” software clock recovery (CR) response; implement Golden PLL per standards
- Analyze the jitter spectrum of clock and data signals using jitter magnitude vs. frequency graphs
- View the spectral distribution of low-frequency jitter and isolate jitter components
- Perform band limited (integrated) TJ/DJ/RJ measurements; user-specified start/stop frequencies

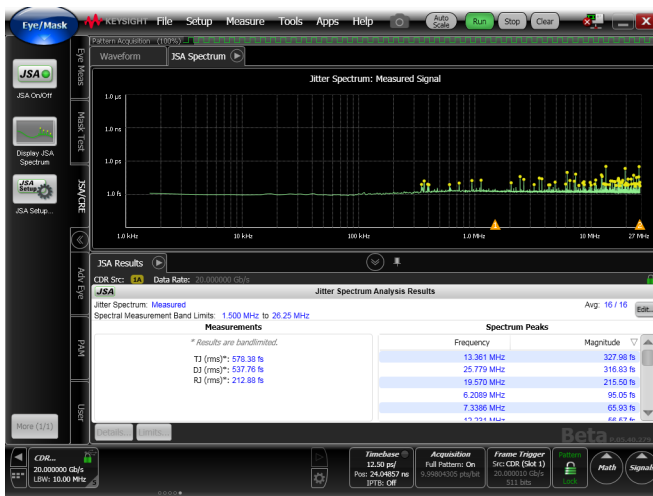

Figure 10. Jitter spectrum analysis (N107xA Option JSA) optimizes Jitter Mode accuracy (N1010100A R&D Package), measures low-frequency jitter (phase noise), and provides insight into the root cause(s) of jitter.

Easily control all settings

The N107x clock recovery instrument is controlled via a rear-panel USB connection to an N1000A DCA-X mainframe or to a standalone PC (Win10/11) running Keysight Technologies N1010A FlexDCA software (no license required for CR control).

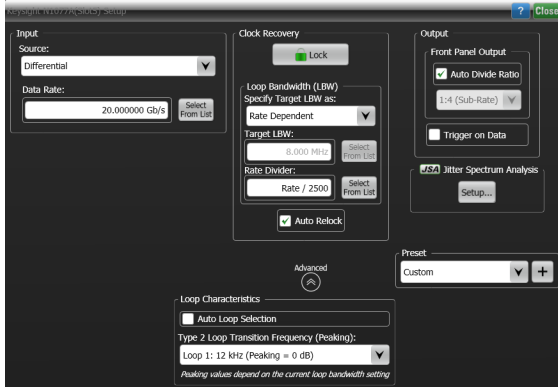

Figure 11. Easily configure the N107x clock recovery data rate, loop bandwidth, and peaking using the N1010A FlexDCA user interface running on an N1000A DCA-X mainframe or standalone PC.

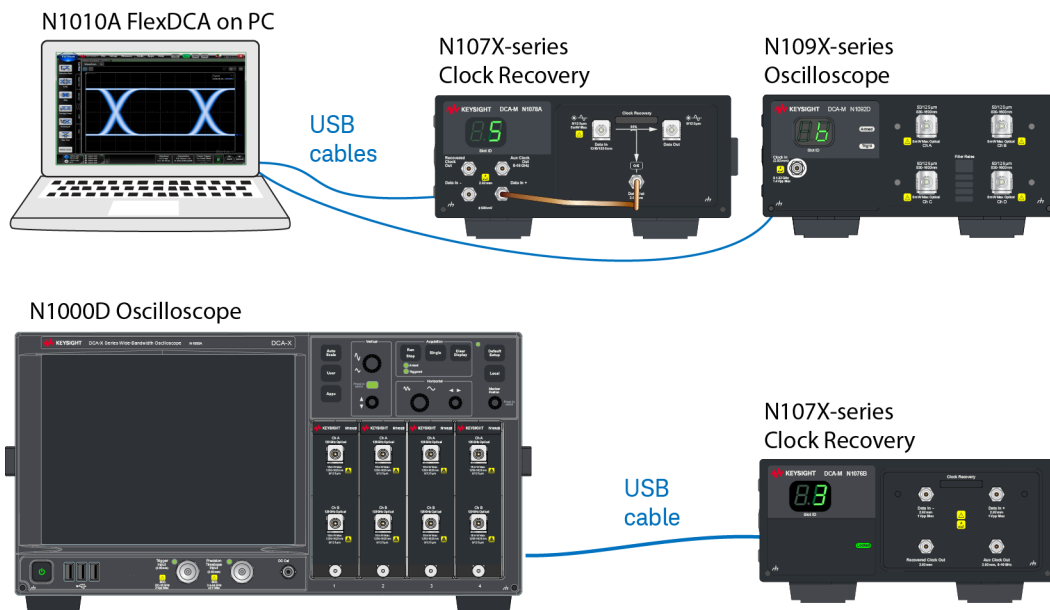

Figure 12. The N107x clock recovery instrument is controlled via a rear-panel USB connection to an N1000A DCA-X mainframe (bottom), or to a standalone PC (top) running the N1010A FlexDCA user interface.

Application Example

Figure 13 on page 16 illustrates clock recovery for sampling scope with high-bandwidth sampling heads and a precision time base. Sampling scopes are the ideal choice for transmitter characterization when high-bandwidth, low noise floor and low intrinsic jitter are required. The N107x, with its ultra-low jitter auxiliary clock output, provides a clean sine wave for a precision time-base module or integrated precision timebase enabling the most accurate measurements (precision timebase is not required). The main recovered clock output, with its divide stages, triggers the front panel trigger input. For additional Application Examples see the *Keysight N107X-Series Clock Recovery DCA-Ms User's Guide*, N1076-90003. Go to www.keysight.com/find/N1077A and click the Resource Center tab.

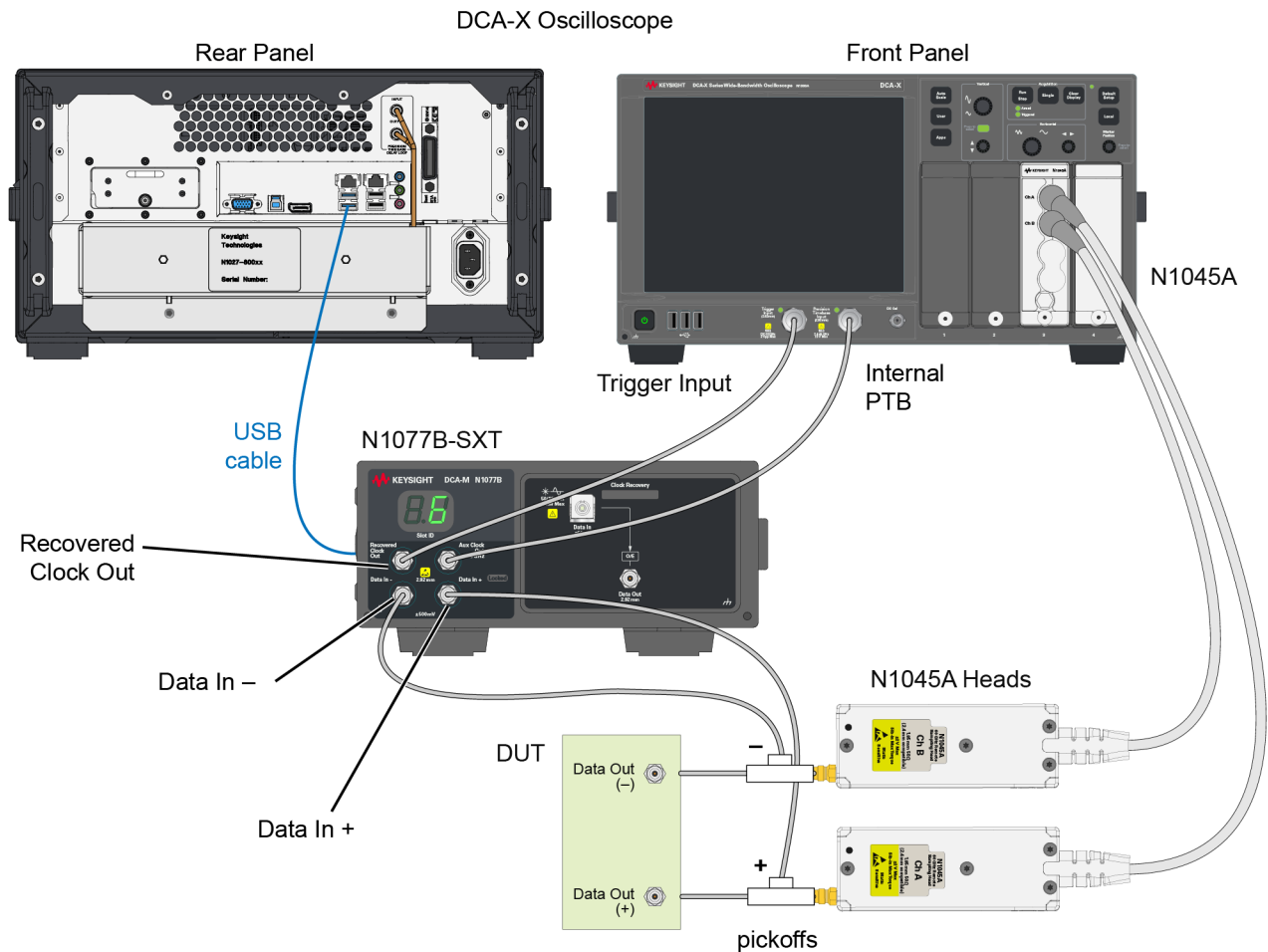

Figure 13. Connection diagram showing an N107x connected to an N1000A DCA-X and remote head modules using high-bandwidth electrical pick-offs (optional accessory).

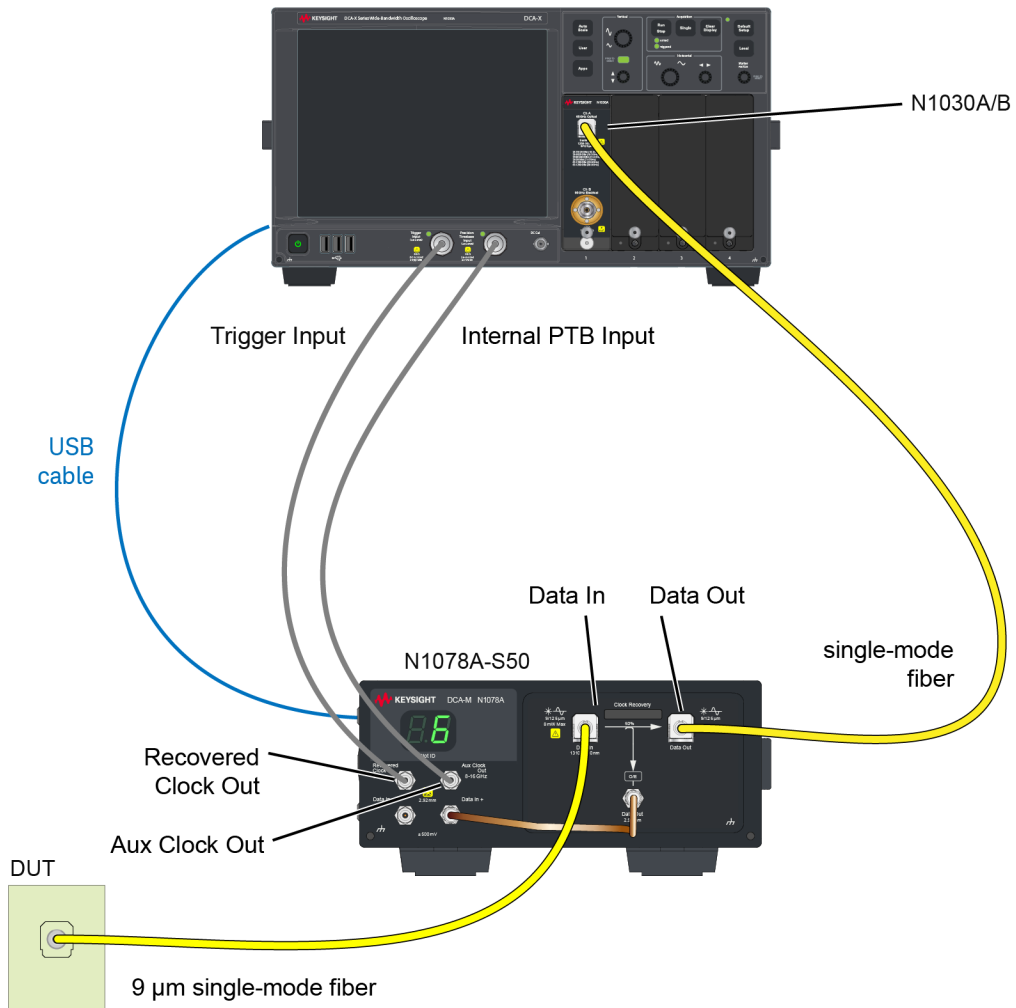

Figure 14. Connection diagram showing an N107x connected to an N1000A DCA-X and N1030A module.

N1076B Specifications

N1076B electrical data input (+/-) specifications

Item	Specification
Data Rate Input Range	Description
Option 264	125 MBd to 64 GBd, <i>125 MBd to 65.6 GBd (characteristic)</i>
Option 232	125 MBd to 32 GBd, <i>125 MBd to 32.8 GBd (characteristic)</i>
Option 216	125 MBd to 16 GBd, <i>125 MBd to 16.4 GBd (characteristic)</i>
Minimum input level to acquire lock (NRZ & PAM4, single-ended, open eye)	Description
Option 264	30 mV pp (rate ≤ 53.125 GBd) 60 mV pp (rate > 53.125 GBd) <i>10 mV pp at 10.3125 GBd (characteristic)</i> <i>10 mV pp at 26.56 GBd (characteristic)</i> <i>20 mV pp at 53.125 GBd (characteristic)</i> <i>25 mV pp at 56 GBd (characteristic)</i> <i>50 mV pp at 64 GBd (characteristic)</i>
Option 232	30 mV pp <i>10 mV pp at 10.3125 GBd (characteristic)</i> <i>10 mV pp at 26.56 GBd (characteristic)</i>
Option 216	30 mV pp <i>10 mV pp at 10.3125 GBd (characteristic)</i>
Minimum input level to acquire lock (PAM4, closed eye)	Description
Option 264	<i>75 mV pp at 26.56 GBd with 20 dB channel loss at 13.28 GHz (characteristic)</i> <i>75 mV pp at 53.125 GBd with 14 dB channel loss at 26.56 GHz (characteristic)</i>
Option 232	<i>75 mV pp at 26.56 GBd with 20 dB channel loss at 13.28 GHz (characteristic)</i>
Option 216	—
Other	Description
Input Voltage Levels (min/max)	± 500 mV (maximum)
Minimum transition density	20%
Interface	Differential or single-ended, DC coupled, 50 Ω
Connector Type	2.92 mm (f)

N1076B recovered clock output specifications

Item	Specification
Clock Output Range	
Option 264, 232	62.5 MHz to 32 GHz <i>62.5 MHz to 32.8 GHz (characteristic)</i>
Option 216	62.5 MHz to 16 GHz <i>62.5 MHz to 16.4 GHz (characteristic)</i>
Recovered Clock Random Jitter	
Option 264, 232	280 fs maximum at ≥ 2.5 GHz <i>150 fs at 26 GHz (characteristic)</i>
Option 216	280 fs maximum at ≥ 2.5 GHz <i>180 fs at 10 GHz (characteristic)</i>
Loop Bandwidth Range (user selectable)	0.015 to 20 MHz (depends on Baud Rate)
Loop Bandwidth Accuracy ^{1, 2} (characteristic, NRZ)	
Option 264	$\pm 30\%$ from 1 to 15 MHz @ 10.3125 GBd $\pm 30\%$ from 1 to 20 MHz @ 26.56 GBd $\pm 30\%$ from 2 to 20 MHz @ 53.125 GBd
Option 232	$\pm 30\%$ from 1 to 15 MHz @ 10.3125 GBd $\pm 30\%$ from 1 to 20 MHz @ 26.56 GBd
Option 216	$\pm 30\%$ from 1 to 15 MHz @ 10.3125 GBd
Clock Recovery Peaking Range	Up to 4 settings (dependent on loop BW)
Tracking Range (includes spread-spectrum tracking)	± 2500 ppm ($\pm 0.25\%$) (characteristic)
Acquisition Range	
Standard Signals	± 300 ppm (characteristic)
Spread Spectrum Signals	± 5000 ppm (characteristic)
Auto Relocking	Yes
Phase Noise Accuracy	$\pm 30\%$ (characteristic, NRZ)
Front Panel Recovered Clock Amplitude	
Option 264, 232	≥ 200 mV pp <i>450 mV pp @ 5 GHz (characteristic)</i> <i>300 mV pp @ 26.56 GHz (characteristic)</i>
Option 216	≥ 200 mV pp <i>450 mV pp @ 5 GHz (characteristic)</i>
Front Panel Recovered Clock Divide Ratio (user selectable)	1, 2, 4, 8, 16, 32
Internal Frequency Counter Accuracy	± 10 ppm
Interface	Single-ended, AC coupled, 50 Ω
Connector Type	2.92 mm (f)

1. PLL bandwidth is calibrated and verified using a clean NRZ, PRBS13 signal.
2. Actual PLL bandwidth may vary due to several factors, including pattern characteristics (low/high transition density), signaling format (PAM4), and signal quality (closed eyes).

N1076B aux clock output specifications ¹

Item	Description
Output Frequency	8 GHz to 16 GHz
Output Voltage	700 mV pp (typical)
Output Jitter	< 80 fs RMS (characteristic)
Interface	Single-ended, DC coupled, 50 Ω
Connector Type	2.92 mm (f)

1. Recovered clock to Aux Clock ratio is always 2^N

N1076B environmental specifications

Item	Description
Use	Indoor
Operating Temperature	10 °C to +40 °C (50 °F to +104 °F)
Non-operating Temperature	-40 °C to +70 °C (-40 °F to +158 °F)
Altitude (Operating)	Up to 4,600 meters (15,000 ft)
Humidity ¹	Maximum Relative Humidity (non-condensing): 95% RH
Volts-Amperes (VA)	48 VA (Typical)
Weight	6.17 kg (13.6 lb) (Typical)
Dimensions	Description
Without front connectors and rear feet	88.26 mm H x 212.5 mm W x 485 mm D (3.48 inch x 8.17 inch x 19.01 inch)
With front 2.92 mm connectors with load and rear feet	103.31 mm H x 219.56 mm W x 517.80 mm D (4.07 inch x 8.64 inch x 20.39 inch)
With front cover and rear feet	110.18 mm H x 219.56 mm W x 550.71 mm D (4.34 inch x 8.64 inch x 21.68 inch)

1. Samples of this product have been type tested in accordance with the Keysight Environmental Test Manual and verified to be robust against the environmental stresses of Storage, Transportation and End-use; those stresses include but are not limited to temperature, humidity, shock, vibration, altitude and power line conditions. Test Methods are aligned with IEC 60068-2 and levels are similar to MIL-PRF-28800F Class 3.

N1076B LINE power specifications

Item	Description
Line Power	100–120 VAC, 50/60/400 Hz 220–240 VAC, 50/60 Hz
Power in Watts	290 Watts Maximum
The products can operate with mains supply voltage fluctuations up to ± 10% of the nominal voltage.	

N1077A Specifications

N1077A electrical data input (+/-) specifications

Item	Option 216	Option 232
Data Rate Input Range	50 MBd to 16 GBd <i>50 MBd to 16.4 GBd (characteristic)</i>	50 MBd to 32 GBd <i>50 MBd to 32.8 GBd (characteristic)</i>
Minimum input level to acquire lock	30 mVpp (rate ≤ 27 GBd) 35 mVpp (rate > 27 GBd) <i>25 mVpp at 25 GBd (characteristic)</i>	
Input Voltage Levels (Min/Max)	± 2.2 Vpp (maximum)	
Minimum transition density	20%	
Interface	Differential or single-ended, AC coupled, 50 Ω	
Connector Type	2.92 mm (f)	

N1077A recovered clock output specifications

Item	Description
Clock Output Range	50 MHz to 16 GHz
Recovered Clock Random Jitter	220 fs maximum at ≥ 2 GBd <i>130 fs at 16 GHz (characteristic)</i>
Loop Bandwidth Range (user selectable)	0.015 to 20 MHz
Loop Bandwidth Accuracy	± 30% (characteristic)
Clock Recovery Peaking Range	Up to 4 settings (dependent on loop BW)
Tracking Range (includes spread-spectrum tracking)	± 2500 ppm ± 0.25% (characteristic)
Acquisition Range	± 5000 ppm (characteristic)
Auto Relocking	Yes
Residual Spread Spectrum	-84 dB ± 3 dB at 33 kHz (characteristic)
Phase Noise Accuracy	30% (characteristic)
Front Panel Recovered Clock Amplitude	≥ 320 mVpp @ 5 GHz
Front Panel Recovered Clock Divide Ratio (user selectable)	1, 2, 4, 8, 16
Internal Frequency Counter Accuracy	± 10 ppm
Interface	Single-ended, AC coupled, 50 Ω
Connector Type	2.92 mm (f)

N1077A aux clock output specifications

Item	Description
Output Frequency	4 GHz to 8 GHz
Output Voltage	550 mVpp (<i>characteristic</i>)
Output Jitter	< 50 fs RMS (<i>characteristic</i>)
Interface	Single-ended, DC coupled, 50 Ω
Connector Type	2.92 mm (f)

N1077A optical data input/output specifications

Item	9/125 μm	50/125 μm
Optical Data Rate Range	Determined by Option 216/232	
Internal Split Ratio (Optical Out / Internal O/E)	50/50 (nominal)	70/30 (nominal)
Optical Signal Type/Mode	Single-Mode only	Single-Mode or Multimode
Wavelength Range	1310 nm (1260 nm to 1360 nm) 1550 nm (1490 nm to 1600 nm)	850 nm (830 nm to 1360 nm) 1310 nm (1260 nm to 1360 nm) 1550 nm (1490 nm to 1600 nm)
Insertion Loss (Option SMS)	4.75 dB 4.0 dB (characteristic)	4.0 dB 2.8 dB (characteristic)
Return Loss	18 dB (characteristic)	16 dB (characteristic)
Minimum Optical Modulation Amplitude (OMA) to achieve lock (Option SMS)	Description	
850 nm		260 μW 170 μW at 25 Gbps (characteristic) 90 μW at 10 Gbps (characteristic)
1310 nm/1550 nm	200 μW 100 μW at 25 Gbps (characteristic) 60 μW at 10 Gbps (characteristic)	200 μW 100 μW at 25 Gbps (characteristic) 60 μW at 10 Gbps (characteristic)
Minimum Optical Modulation Amplitude (OMA) to achieve lock (Option SXT)	Description	
850 nm		90 μW 53 μW at 25 Gbps (characteristic) 33 μW at 10 Gbps (characteristic)
1310 nm/1550 nm	80 μW 43 μW at 25 Gbps (characteristic) 23 μW at 10 Gbps (characteristic)	80 μW 43 μW at 25 Gbps (characteristic) 23 μW at 10 Gbps (characteristic)
Maximum Input Power	8 mW	8 mW
Maximum Non-destruct Peak	8 mW	8 mW
Optical-to-Electrical Conversion Gain	Description	
Option SMS	180 V/W (characteristic)	120 V/W (characteristic)
Option SXT	550 V/W (characteristic)	360 V/W (characteristic)
Optical Input/Output Connector Type	FC/PC 9/125 μm	FC/PC 50/125 μm
Electrical O/E - Output Connector Type	2.92 mm (f)	

N1077A environmental specifications

Item	Description
Use	indoor
Operating Temperature	10 °C to +40 °C (50 °F to +104 °F)
Non-operating Temperature	-40 °C to +70 °C (-40 °F to +158 °F)
Altitude (Operating)	Up to 4,600 meters (15,000 ft)
Humidity ¹	Maximum Relative Humidity (non-condensing): 95% RH
Volts-Amperes (VA) (<i>Characteristic</i>)	52 VA
Weight (<i>Characteristic</i>)	
N1077A-SMS	6.3 kg (13.8 lb)
N1077A-SXT	6.1 kg (13.4 lb)
Dimensions	
Without front connectors and rear feet	88.26 mm H x 207.40 mm W x 485 mm D (3.48 inch x 8.17 inch x 19.01 inch)
With front connectors and rear feet	103.31 mm H x 219.56 mm W x 517.80 mm D (4.07 inch x 8.64 inch x 20.39 inch)
With front cover and rear feet	110.18 mm H x 219.56 mm W x 550.71 mm D (4.34 inch x 8.64 inch x 21.68 inch)

1. Samples of this product have been type tested in accordance with the Keysight Environmental Test Manual and verified to be robust against the environmental stresses of Storage, Transportation and End-use; those stresses include but are not limited to temperature, humidity, shock, vibration, altitude and power line conditions. Test Methods are aligned with IEC 60068-2 and levels are similar to MIL-PRF-28800F Class 3.

N1077A LINE power specifications

Item	Description
Line Power	100–120 Vac, 50/60/400 Hz 220–240 Vac, 50/60 Hz
Power in Watts	290 Watts Maximum
The products can operate with mains supply voltage fluctuations up to $\pm 10\%$ of the nominal voltage.	

N1077B Specifications

N1077B electrical data input (+/-)

Item	Specification
Data Rate Input Range	
	Description
Option 264	125 MBd to 64 GBd, 125 MBd to 65.6 GBd (characteristic)
Option 253	48 GBd to 58 GBd
Option 232	125 MBd to 32 GBd, 125 MBd to 32.8 GBd (characteristic)
Option 225	24 GBd to 29 GBd
Option 216	125 MBd to 16 GBd, 125 MBd to 16.4 GBd (characteristic)
Minimum input level to acquire lock (NRZ & PAM4, single-ended, open eye)	
	Description
Option 264	30 mV pp (rate ≤ 53.125 GBd) 60 mV pp (rate > 53.125 GBd) 10 mV pp at 10.3125 GBd (characteristic) 10 mV pp at 26.56 GBd (characteristic) 20 mV pp at 53.125 GBd (characteristic) 25 mV pp at 56 GBd (characteristic) 50 mV pp at 64 GBd (characteristic)
Option 253	60 mV pp 20 mV pp at 53.125 GBd (characteristic) 25 mV pp at 56 GBd (characteristic)
Option 232	30 mV pp 10 mV pp at 10.3125 GBd (characteristic) 10 mV pp at 26.56 GBd (characteristic)
Option 225	30 mV pp 10 mV pp at 26.56 GBd (characteristic)
Option 216	30 mV pp 10 mV pp at 10.3125 GBd (characteristic)
Minimum input level to acquire lock (PAM4, closed eye)	
	Description
Option 264	75 mV pp at 26.56 GBd with 20 dB channel loss at 13.28 GHz (characteristic) 75 mV pp at 53.125 GBd with 14 dB channel loss at 26.56 GHz (characteristic)
Option 253	75 mV pp at 53.125 GBd with 14 dB channel loss at 26.56 GHz (characteristic)
Option 232	75 mV pp at 26.56 GBd with 20 dB channel loss at 13.28 GHz (characteristic)
Option 225	75 mV pp at 26.56 GBd with 20 dB channel loss at 13.28 GHz (characteristic)
Other	
	Description
Input Voltage Levels (min/max)	± 500 mV (maximum)
Interface	Differential or single-ended, DC coupled, 50 Ω
Connector Type	2.92 mm (f)

N1077B optical data input/output specifications

Item	Description
Data Rate Input Range	
Description	
Option 264	125 MBd to 64 GBd <i>125 MBd to 65.6 GBd (characteristic)</i>
Option 253	48 GBd to 58 GBd
Option 232	125 MBd to 32 GBd <i>125 MBd to 32.8 GBd (characteristic)</i>
Option 225	24 GBd to 29 GBd
Option 216	125 MBd to 16 GBd <i>125 MBd to 16.4 GBd (characteristic)</i>
Internal Split Ratio (Option SMM) (Optical Out / Internal O/E)	70/30 (nominal)
Wavelength Range	
Description	
Option SMM	830 nm – 950 nm ¹ 1260 nm – 1340 nm ²
Option SXT	830 nm – 1340 nm ²
Insertion Loss (Option SMM)	4.0 dB <i>2.5 dB (characteristic)</i>
Return Loss	<i>16 dB (characteristic)</i>
Maximum Input Power	
Description	
Option SMM	8 mW
Option SXT	5 mW
Optical Input/Output Connector Type	FC/PC 50/125 μm
O/E Data Output Connector Type	2.92 mm (f)

1. Insertion loss is specified at 850 nm. Option SMM insertion loss may degrade by approximately 2 dB at wavelengths above 900 nm.
2. Clock Pattern Distortion Compensation feature must be enabled for single-mode wavelength.

N1077B minimum optical modulation amplitude (OMA) to achieve lock (Option SMM)

Item	Description			
NRZ and PAM4 (OMA) 850 nm				
	Description			
Option 264	200 μ W (rate \leq 53.125 GBd) 400 μ W (53.125 GBd < rate \leq 59 GBd) 60 μ W at 10.3125 GBd (characteristic) 80 μ W at 26.56 GBd (characteristic) 80 μ W at 53.125 GBd (characteristic) 150 μ W at 56 GBd (characteristic) 300 μ W at 64 GBd (characteristic)			
Option 253	400 μ W 80 μ W at 53.125 GBd (characteristic) 150 μ W at 56 GBd (characteristic)			
Option 232	200 μ W 60 μ W at 10.3125 GBd (characteristic) 80 μ W at 26.56 GBd (characteristic)			
Option 225	200 μ W 80 μ W at 26.56 GBd (characteristic)			
Option 216	200 μ W 60 μ W at 10.3125 GBd (characteristic)			
PAM4 Stressed Eye 850 nm (Clock recovery locks under these conditions)				
	Description			
	Baud Rate Pattern Outer OMA TDECQ			
Option 264	26.56 GBd	SSPRQ	-5.1 dBm	~3.4 dB
	53.125 GBd	SSPRQ	-0.8 dBm	~3.4 dB
Option 253	53.125 GBd	SSPRQ	-0.8 dBm	~3.4 dB
Options 225, 232	26.56 GBd	SSPRQ	-5.1 dBm	~3.4 dB

N1077B minimum optical modulation amplitude (OMA) to achieve lock (Option SXT)

Item	Description			
NRZ and PAM4 (OMA) 850 nm				
	Description			
Option 264	100 μ W (rate \leq 53.125 GBd) 200 μ W (53.125 GBd < rate \leq 59 GBd) 30 μ W at 10.3125 GBd (characteristic) 40 μ W at 26.56 GBd (characteristic) 40 μ W at 53.125 GBd (characteristic) 75 μ W at 56 GBd (characteristic) 150 μ W at 64 GBd (characteristic)			
Option 253	200 μ W 40 μ W at 53.125 GBd (characteristic) 75 μ W at 56 GBd (characteristic)			
Option 232	100 μ W 30 μ W at 10.3125 GBd (characteristic) 40 μ W at 26.56 GBd (characteristic)			
Option 225	100 μ W 40 μ W at 26.56 GBd (characteristic)			
Option 216	100 μ W 30 μ W at 10.3125 GBd (characteristic)			
PAM4 Stressed Eye 850 nm ¹ (Clock recovery locks under these conditions)				
	Description			
	Baud Rate Pattern Outer OMA TDECQ			
Option 264	26.56 GBd	SSPRQ	-5.1 dBm	~3.4 dB
	53.125 GBd	SSPRQ	-0.8 dBm	~3.4 dB
Option 253	53.125 GBd	SSPRQ	-0.8 dBm	~3.4 dB
Options 225, 232	26.56 GBd	SSPRQ	-5.1 dBm	~3.4 dB

1. Option SXT is tested with an external 70/30 splitter – the same 70/30 splitter internal to the option SMM. If using a splitter with a different ratio, the sensitivity will vary accordingly.

N1077B recovered clock output specifications

Item	Specification
Clock Output Range	
	Description
Option 264	62.5 MHz to 32 GHz <i>62.5 MHz to 32.8 GHz (characteristic)</i>
Option 253	24 GHz to 29 GHz and subrates
Option 232	62.5 MHz to 32 GHz <i>62.5 MHz to 32.8 GHz (characteristic)</i>
Option 225	24 GHz to 29 GHz and subrates
Option 216	62.5 MHz to 16 GHz <i>62.5 MHz to 16.4 GHz (characteristic)</i>
Recovered Clock Random Jitter	
	Description
Options 225, 232, 253, 264	280 fs maximum (≥ 2.5 GHz) <i>150 fs at 26 GHz (characteristic)</i>
Option 216	280 fs maximum (≥ 2.5 GHz) <i>180 fs at 10 GHz (characteristic)</i>
Loop Bandwidth Range (user selectable)	0.015 to 20 MHz (depends on baud rate)
Loop Bandwidth Accuracy ^{1, 2} (characteristic)	
	Description
Option 264	$\pm 30\%$ from 1 to 15 MHz @ 10.3125 GBd $\pm 30\%$ from 1 to 15 MHz @ 26.56 GBd $\pm 30\%$ from 2 to 15 MHz @ 53.125 GBd
Option 253	$\pm 30\%$ from 2 to 15 MHz @ 53.125 GBd
Option 232	$\pm 30\%$ from 1 to 15 MHz @ 10.3125 GBd $\pm 30\%$ from 1 to 15 MHz @ 26.56 GBd
Option 225	$\pm 30\%$ from 1 to 15 MHz @ 26.56 GBd
Option 216	$\pm 30\%$ from 1 to 15 MHz @ 10.3125 GBd
Clock Recovery Peaking Range	Up to 4 settings (dependent on loop BW)
Tracking Range (includes spread-spectrum tracking)	± 2500 ppm ($\pm 0.25\%$) (characteristic)
Acquisition Range	
	Description
Standard Signals	± 300 ppm (characteristic)
Spread Spectrum Signals (electrical only)	± 5000 ppm (characteristic)
Auto Relocking	Yes
Phase Noise Accuracy (open eye, electrical only)	$\pm 30\%$ (characteristic, NRZ)
Front Panel Recovered Clock Amplitude	
	Description
Options 225, 232, 253, 264	≥ 200 mV pp <i>450 mV pp @ 5 GHz (characteristic)</i> <i>300 mV pp @ 26.56 GHz (characteristic)</i>
Option 216	≥ 200 mV pp <i>450 mV pp @ 5 GHz (characteristic)</i>
Front Panel Recovered Clock Divide Ratio (user selectable)	1, 2, 4, 8, 16, 32
Internal Frequency Counter Accuracy	± 10 ppm ± 2 ppm (characteristic)

Recovered Clock Interface	Single-ended, AC coupled, 50 Ω
Connector Type	2.92 mm (f)

1. PLL bandwidth is calibrated and verified using a clean NRZ, PRBS13 signal.
2. Actual PLL bandwidth untuned may vary due to several factors, including pattern characteristics (low/high transition density), signaling format (PAM4), and signal quality (closed eyes). For more accurate electrical and optical LBW, tuned LBW is always recommended.

N1077B aux clock interface output

Recovered clock to Aux Clock ratio is always 2^N .

Item	Description
Output Frequency	8 GHz to 16 GHz
Output Voltage	700 mV pp @ 13.28 GHz (characteristic)
Output Jitter	< 80 fs RMS (characteristic)
Aux Clock Interface	Single-ended, DC coupled, 50 Ω
Connector Type	2.92 mm (f)

N1077B environmental specifications

Item	Description
Use	Indoor
Operating Temperature	10 °C to +40 °C (50 °F to +104 °F)
Non-operating Temperature	-40 °C to +70 °C (-40 °F to +158 °F)
Altitude (Operating)	Up to 4,600 meters (15,000 ft)
Humidity ¹	Maximum Relative Humidity (non-condensing): 95% RH
Volts-Amperes (VA)	52 VA (Typical)
Weight	Description
N1077B-SMM	6.4 kg (14.2 lb) (Typical)
N1077B-SXT	6.4 kg (14.2 lb) (Typical)
Dimensions	Description
Without front connectors and rear feet	88.26 mm H x 212.5 mm W x 485 mm D (3.48 inch x 8.37 inch x 19.01 inch)
With front connectors, jumper cable (Data Out to Data In +), and rear feet	103.31 mm H x 219.56 mm W x 532.8 mm D (4.07 inch x 8.64 inch x 20.97 inch)
With front cover and rear feet	110.18 mm H x 219.56 mm W x 550.71 mm D (4.34 inch x 8.64 inch x 21.68 inch)

1. Samples of this product have been type tested in accordance with the Keysight Environmental Test Manual and verified to be robust against the environmental stresses of Storage, Transportation and End-use; those stresses include but are not limited to temperature, humidity, shock, vibration, altitude and power line conditions. Test Methods are aligned with IEC 60068-2 and levels are similar to MIL-PRF-28800F Class 3.

N1077B LINE power specifications

Item	Description
Line Power	100–120 VAC, 50/60/400 Hz 220–240 VAC, 50/60 Hz
Power in Watts	290 Watts Maximum
The products can operate with mains supply voltage fluctuations up to $\pm 10\%$ of the nominal voltage.	

N1078A Specifications

N1078A electrical data input (+/-)

Item	Specification
Data Rate Input Range	
	Description
Option 264	125 MBd to 64 GBd, 125 MBd to 65.6 GBd (characteristic)
Option 253	53 GBd to 58 GBd
Option 232	125 MBd to 32 GBd, 125 MBd to 32.8 GBd (characteristic)
Option 225	25 GBd to 29 GBd
Option 216	125 MBd to 16 GBd, 125 MBd to 16.4 GBd (characteristic)
Minimum input level to acquire lock (NRZ & PAM4, single-ended, open eye)	
	Description
Option 264	30 mV pp (rate ≤ 53.125 GBd) 60 mV pp (rate > 53.125 GBd) 10 mV pp at 10.3125 GBd (characteristic) 10 mV pp at 26.56 GBd (characteristic) 20 mV pp at 53.125 GBd (characteristic) 25 mV pp at 56 GBd (characteristic) 50 mV pp at 64 GBd (characteristic)
Option 253	60 mV pp 20 mV pp at 53.125 GBd (characteristic) 25 mV pp at 56 GBd (characteristic)
Option 232	30 mV pp 10 mV pp at 10.3125 GBd (characteristic) 10 mV pp at 26.56 GBd (characteristic)
Option 225	30 mV pp 10 mV pp at 26.56 GBd (characteristic)
Option 216	30 mV pp 10 mV pp at 10.3125 GBd (characteristic)
Minimum input level to acquire lock (PAM4, closed eye)	
	Description
Option 264	75 mV pp at 26.56 GBd with 20 dB channel loss at 13.28 GHz (characteristic) 75 mV pp at 53.125 GBd with 14 dB channel loss at 26.56 GHz (characteristic)
Option 253	75 mV pp at 53.125 GBd with 14 dB channel loss at 26.56 GHz (characteristic)
Options 232, 225	75 mV pp at 26.56 GBd with 20 dB channel loss at 13.28 GHz (characteristic)
Option 216	—
Other	
	Description
Input Voltage Levels (min/max)	± 500 mV (maximum)
Minimum transition density	20%
Interface	Differential or single-ended, DC coupled, 50 Ω
Connector Type	2.92 mm (f)

N1078A optical data input/output specifications

Item	Description
Data Rate Input Range	Description
Option 264	125 MBd to 64 GBd, <i>125 MBd to 65.6 GBd (characteristic)</i>
Option 253	53 GBd to 58 GBd
Option 232	125 MBd to 32 GBd, <i>125 MBd to 32.8 GBd (characteristic)</i>
Option 225	25 GBd to 29 GBd
Option 216	125 MBd to 16 GBd, <i>125 MBd to 16.4 GBd (characteristic)</i>
Internal Split Ratio (Option S50) (Optical Out / Internal O/E)	50/50 (nominal)
Optical Signal Type/Mode	Single-Mode only
Wavelength Range	1260 nm to 1620 nm. Tested at 1310 nm and 1550 nm.
Insertion Loss (Option S50)	4.75 dB, <i>3.5 dB (characteristic)</i>
Return Loss	<i>16 dB (characteristic)</i>
Maximum Input Power	8 mW (option S50) 4 mW (option SXT)
Optical Input/Output Connector Type	FC/PC 9/125 μ m
Electrical O/E - Output Connector Type	2.92 mm (f)

N1078A minimum optical modulation amplitude (OMA) to achieve lock (Option S50)

Item	Description			
NRZ and PAM4 (OMA) 1310 nm/1550 nm				
Description				
Option 264	200 μ W (rate \leq 53.125 GBd) 400 μ W (53.125 GBd < rate \leq 59 GBd) 60 μ W at 10.3125 GBd (characteristic) 80 μ W at 26.56 GBd (characteristic) 80 μ W at 53.125 GBd (characteristic) 150 μ W at 56 GBd (characteristic) 300 μ W at 64 GBd (characteristic)			
Option 253	400 μ W 80 μ W at 53.125 GBd (characteristic) 150 μ W at 56 GBd (characteristic)			
Option 232	200 μ W 60 μ W at 10.3125 GBd (characteristic) 80 μ W at 26.56 GBd (characteristic)			
Option 225	200 μ W 80 μ W at 26.56 GBd (characteristic)			
Option 216	200 μ W 60 μ W at 10.3125 GBd (characteristic)			
PAM4 Stressed Eye 1310 nm/1550 nm (Clock recovery locks under these conditions)				
	Baud Rate	Pattern	Outer OMA	TDECQ
Option 264	26.56 GBd	SSPRQ	-5.1 dBm	~3.4 dB
	53.125 GBd	SSPRQ	-0.8 dBm	~3.4 dB
Option 253	53.125 GBd	SSPRQ	-0.8 dBm	~3.4 dB
Options 225, 232	26.56 GBd	SSPRQ	-5.1 dBm	~3.4 dB

N1078A minimum optical modulation amplitude (OMA) to achieve lock (Option SXT)

Item	Description			
NRZ and PAM4 (OMA) 1310 nm/1550 nm				
	Description			
Option 264	100 μ W (rate \leq 53.125 GBd) 200 μ W (53.125 GBd < rate \leq 59 GBd) 30 μ W at 10.3125 GBd (characteristic) 40 μ W at 26.56 GBd (characteristic) 40 μ W at 53.125 GBd (characteristic) 75 μ W at 56 GBd (characteristic) 150 μ W at 64 GBd (characteristic)			
Option 253	200 μ W 40 μ W at 53.125 GBd (characteristic) 75 μ W at 56 GBd (characteristic)			
Option 232	100 μ W 30 μ W at 10.3125 GBd (characteristic) 40 μ W at 26.56 GBd (characteristic)			
Option 225	100 μ W 40 μ W at 26.56 GBd (characteristic)			
Option 216	100 μ W 30 μ W at 10.3125 GBd (characteristic)			
PAM4 Stressed Eye 1310 nm/1550 nm ¹ (Clock recovery locks under these conditions)				
	Baud Rate	Pattern	Outer OMA	TDECQ
Option 264	26.56 GBd	SSPRQ	-5.1 dBm	~3.4 dB
	53.125 GBd	SSPRQ	-0.8 dBm	~3.4 dB
Option 253	53.125 GBd	SSPRQ	-0.8 dBm	~3.4 dB
Options 225, 232	26.56 GBd	SSPRQ	-5.1 dBm	~3.4 dB

1. Option SXT is tested with an external 50/50 splitter – the same 50/50 splitter internal to the option S50. If using a splitter with a different ratio, the sensitivity will vary accordingly.

N1078A recovered clock output specifications

Item	Specification
Clock Output Range	
	Description
Option 264	62.5 MHz to 32 GHz <i>62.5 MHz to 32.8 GHz (characteristic)</i>
Option 253	26.5 GHz to 29 GHz and subrates
Option 232	62.5 MHz to 32 GHz <i>62.5 MHz to 32.8 GHz (characteristic)</i>
Option 225	25 GHz to 29 GHz and subrates
Option 216	62.5 MHz to 16 GHz <i>62.5 MHz to 16.4 GHz (characteristic)</i>
Recovered Clock Random Jitter	
	Description
Options 225, 232, 253, 264	280 fs maximum (≥ 2.5 GHz) <i>150 fs at 26 GHz (characteristic)</i>
Option 216	280 fs maximum (≥ 2.5 GHz) <i>180 fs at 10 GHz (characteristic)</i>
Loop Bandwidth Range (user selectable)	0.015 to 20 MHz (depends on Baud Rate)
Loop Bandwidth Accuracy ^{1, 2} (characteristic, NRZ)	
	Description
Option 264	$\pm 30\%$ from 1 to 15 MHz @ 10.3125 GBd $\pm 30\%$ from 1 to 20 MHz @ 26.56 GBd $\pm 30\%$ from 2 to 20 MHz @ 53.125 GBd
Option 253	$\pm 30\%$ from 2 to 20 MHz @ 53.125 GBd
Option 232	$\pm 30\%$ from 1 to 15 MHz @ 10.3125 GBd $\pm 30\%$ from 1 to 20 MHz @ 26.56 GBd
Option 225	$\pm 30\%$ from 1 to 20 MHz @ 26.56 GBd
Option 216	$\pm 30\%$ from 1 to 15 MHz @ 10.3125 GBd
Clock Recovery Peaking Range	Up to 4 settings (dependent on loop BW)
Tracking Range (includes spread-spectrum tracking)	± 2500 ppm ($\pm 0.25\%$) (characteristic)
Acquisition Range	
	Description
Standard Signals	± 300 ppm (characteristic)
Spread Spectrum Signals	± 5000 ppm (characteristic)
Auto Relocking	Yes
Phase Noise Accuracy	$\pm 30\%$ (characteristic, NRZ)
Front Panel Recovered Clock Amplitude	
	Description
Options 225, 232, 253, 264	≥ 200 mV pp <i>450 mV pp @ 5 GHz (characteristic)</i> <i>300 mV pp @ 26.56 GHz (characteristic)</i>
Option 216	≥ 200 mV pp <i>450 mV pp @ 5 GHz (characteristic)</i>

Front Panel Recovered Clock Divide Ratio (user selectable)	1, 2, 4, 8, 16, 32
Internal Frequency Counter Accuracy	± 10 ppm
Interface	Single-ended, AC coupled, 50 Ω
Connector Type	2.92 mm (f)

1. PLL bandwidth is calibrated and verified using a clean NRZ, PRBS13 signal.
2. Actual PLL bandwidth may vary due to several factors, including pattern characteristics (low/high transition density), signaling format (PAM4), and signal quality (closed eyes).

N1078A aux clock output ¹

Item	Description
Output Frequency	8 GHz to 16 GHz
Output Voltage	700 mV pp @ 13.28 GHz (characteristic)
Output Jitter	< 80 fs RMS (characteristic)
Interface	Single-ended, DC coupled, 50 Ω
Connector Type	2.92 mm (f)

1. Recovered clock to Aux Clock ratio is always 2^N.

N1078A environmental specifications

Item	Description
Use	Indoor
Operating Temperature	10 °C to +40 °C (50 °F to +104 °F)
Non-operating Temperature	-40 °C to +70 °C (-40 °F to +158 °F)
Altitude (Operating)	Up to 4,600 meters (15,000 ft)
Humidity ¹	Maximum Relative Humidity (non-condensing): 95% RH
Volts-Amperes (VA)	52 VA (Typical)
Weight	Description
N1078A-S50	6.4 kg (14.2 lb) (Typical)
N1078A-SXT	6.4 kg (14.2 lb) (Typical)
Dimensions	Description
Without front connectors and rear feet	88.26 mm H x 212.5 mm W x 485 mm D (3.48 inch x 8.37 inch x 19.01 inch)
With front connectors, jumper cable (Data Out to Data In +), and rear feet	103.31 mm H x 219.56 mm W x 532.8 mm D (4.07 inch x 8.64 inch x 20.97 inch)
With front cover and rear feet	110.18 mm H x 219.56 mm W x 550.71 mm D (4.34 inch x 8.64 inch x 21.68 inch)

1. Samples of this product have been type tested in accordance with the Keysight Environmental Test Manual and verified to be robust against the environmental stresses of Storage, Transportation and End-use; those stresses include but are not limited to temperature, humidity, shock, vibration, altitude and power line conditions. Test Methods are aligned with IEC 60068-2 and levels are similar to MIL-PRF-28800F Class 3.

N1078A LINE power specifications

Item	Description
Line Power	100–120 VAC, 50/60/400 Hz 220–240 VAC, 50/60 Hz
Power in Watts	290 Watts Maximum
The products can operate with mains supply voltage fluctuations up to $\pm 10\%$ of the nominal voltage.	

Ordering Information

N1076B configurations

Model number	Description
N1076B	Electrical clock recovery
Baud rate (choose one)	Description
N1076B-216	Supported input rates: 125 MBd to 16 GBd
N1076B-232	Supported input rates: 125 MBd to 32 GBd
N1076B-264	Supported input rates: 125 MBd to 64 GBd
Advanced options	Description
N1076B-EVA	Integrated variable equalizer
JSA	Jitter spectrum analysis will be enabled by N1010100A or N1010300A
Optional accessories	Description
N1076B-CR1	Clock recovery phase matching kit
N1076B-2P1	Microwave pick-off tee 1.0 mm connectors, matched pair (re-order N1027A-2P1)
N1076B-2P2	Microwave pick-off tee 2.4 mm connectors, matched pair (re-order N1027A-2P2)
N1076B-2P3	Microwave pick-off tee 2.92 mm connectors, matched pair (re-order N1027A-2P3)
N1076B-2P8	Microwave pick-off tee 1.85 mm connectors, matched pair (re-order N1027A-2P8)
N1076B-EQ3	Equalizer, 2.92 mm (m) to 2.92 mm (f), 3 dB
N1076B-EQ6	Equalizer, 2.92 mm (m) to 2.92 mm (f), 6 dB
N1076B-EQ9	Equalizer, 2.92 mm (m) to 2.92 mm (f), 9 dB
N1076B-1CM	Single DCA-M rack mount kit (re-order N1027A-RM1)
N1076B-1CN	Dual DCA-M side by side rack mount kit (re-order N1027A-RM2)
N1076B-C0C	Certificate of calibration
N1076B-UK6	Commercial calibration certificate with test data
R1280A	Return to Keysight service center - warranty and service plan
R1282A	Return to Keysight service center - calibration plan

N1077A configurations

Model number	Description
N1077A	Optical/electrical clock recovery
Baud rate (choose one)	Description
N1077A-216	Supported input rates: 50 MBd to 16 GBd
N1077A-232	Supported input rates: 50 MBd to 32 GBd
Splitter options (choose one)	Description
N1077A-SMS	Internal single-mode (9/125 μm) and multimode (50/125 μm) splitter
N1077A-SXT	External splitter (supplied by customer)
Advanced options	Description
JSA	Jitter spectrum analysis will be enabled by N1010100A or N1010300A
Optional accessories	Description
N1077A-CR1	Clock recovery phase matching kit for N1077A optical (re-order N1027A-77A). Kit includes optical delay matching SM/MM cables, one 6-dB equalizer, one 9-dB equalizer.
N1077A-EQ6	Equalizer, 2.92 mm (m) to 2.92 mm (f), 6 dB (re-order N1027A-EQ6)
N1077A-EQ9	Equalizer, 2.92 mm (m) to 2.92 mm (f), 9 dB (re-order N1027A-EQ9)
N1077A-1CM	Single DCA-M rack mount kit (re-order N1027A-RM1)
N1077A-1CN	Dual DCA-M side by side rack mount kit (re-order N1027A-RM2)
N1077A-C0C	Certificate of calibration
N1077A-UK6	Commercial calibration certificate with test data
R1280A	Return to Keysight service center - warranty and service plan
R1282A	Return to Keysight service center - calibration plan

N1077B configurations

Model number	Description
N1077B	Optical/electrical clock recovery
Baud rate (choose one)	Description
N1077B-216	Supported input rates: 125 MBd to 16 GBd
N1077B-225	Supported input rates 24 GBd to 29 GBd
N1077B-232	Supported input rates: 125 MBd to 32 GBd
N1077B-253	Supported input rates 48 GBd to 58 GBd
N1077B-264	Supported input rates: 125 MBd to 64 GBd
Splitter options (choose one)	Description
N1077B-SMM	Internal 70/30 splitter
N1077B-SXT	External splitter
Advanced options	Description
N1077B-EVA	Integrated variable equalizer
JSA	Jitter spectrum analysis will be enabled by N1010100A or N1010300A
Optional accessories	Description
N1077B-CR1	Clock recovery phase matching kit for N1077B
N1077B-EQ3	Equalizer, 2.92 mm (m) to 2.92 mm (f), 3 dB (re-order N1027A-EQ3)
N1077B-EQ6	Equalizer, 2.92 mm (m) to 2.92 mm (f), 6 dB (re-order N1027A-EQ6)
N1077B-EQ9	Equalizer, 2.92 mm (m) to 2.92 mm (f), 9 dB (re-order N1027A-EQ9)
N1077B-1CM	Single DCA-M rack mount kit (re-order N1027A-RM1)
N1077B-1CN	Dual DCA-M side by side rack mount kit (re-order N1027A-RM2)
N1077B-C0C	Certificate of calibration
N1077B-UK6	Commercial calibration certificate with test data
R1280A	Return to Keysight service center - warranty and service plan
R1282A	Return to Keysight service center - calibration plan

N1078A configurations

Model number	Description
N1078A	Optical/electrical clock recovery
Baud rate (choose one)	Description
N1078A-216	Supported input rates: 125 MBd to 16 GBd
N1078A-225	Supported input rates: 25 GBd to 29 GBd
N1078A-232	Supported input rates: 125 MBd to 32 GBd
N1078A-253	Supported input rates: 53 GBd 58 GBd
N1078A-264	Supported input rates: 125 MBd to 64 GBd
Splitter options (choose one)	Description
N1078A-S50	Internal single-mode splitter 50 percent to optical output, 9/125 μ m
N1078A-SXT	External splitter
Advanced options	Description
N1078A-EVA	Integrated variable equalizer
JSA	Jitter spectrum analysis will be enabled by N1010100A or N1010300A
Optional accessories	Description
N1078A-CR1	Clock recovery phase matching kit for N1078A
N1078A-EQ3	Equalizer, 2.92 mm (m) to 2.92 mm (f), 3 dB (re-order N1027A-EQ3)
N1078A-EQ6	Equalizer, 2.92 mm (m) to 2.92 mm (f), 6 dB (re-order N1027A-EQ6)
N1078A-EQ9	Equalizer, 2.92 mm (m) to 2.92 mm (f), 9 dB (re-order N1027A-EQ9)
N1078A-1CM	Single DCA-M rack mount kit (re-order N1027A-RM1)
N1078A-1CN	Dual DCA-M side by side rack mount kit (re-order N1027A-RM2)
N1078A-C0C	Certificate of calibration
N1078A-UK6	Commercial calibration certificate with test data
R1280A	Return to Keysight service center - warranty and service plan
R1282A	Return to Keysight service center - calibration plan

N1076/7/8 clock recovery instruments are controlled via a USB connection to a DCA-X mainframe, or to a standalone PC, running N1010A FlexDCA software. The latest version of FlexDCA may be downloaded from: www.keysight.com/find/flexdca_download.

Accessories

For accessories, please see the DCA Accessory Guide, pub number 5991-2340EN.

Confidently Covered by Keysight Services

Prevent delays caused by technical questions, or system downtime due to instrument maintenance and repairs with Keysight Services. Keysight Services are here to support your test needs with expert technical support, instrument repair and calibration, software support, training, alternative acquisition program options, and more.

A KeysightCare agreement provides dedicated, proactive support through a single point of contact for instruments, software, and solutions. KeysightCare covers an extensive group of instruments, application software, and solutions and ensures optimal uptime, faster response, faster access to experts, and faster resolution.

Keysight Services

Offering	Benefits
KeysightCare 	KeysightCare provides elevated support for Keysight instruments and software, with access to technical support experts that respond within a specified time and ensure committed repair and calibration turnaround times (TAT). KeysightCare offers multiple service agreement tiers, including KeysightCare Assured, Enhanced, and Application Software Support. See the KeysightCare data sheet for details.
KeysightCare Assured	KeysightCare Assured goes beyond basic warranty with repair services that include committed TAT and unlimited access to technical experts.
KeysightCare Enhanced	KeysightCare Enhanced includes all the benefits of KeysightCare Assured plus Keysight’s accurate and reliable calibration services, accelerated, and committed TAT, and technical response.
Keysight Support Portal & Knowledge Center	All KeysightCare tiers include access to the Keysight Support Portal where you can manage support and service resources related to your assets such as service requests, and status, or browse the Knowledge Center.
Education Services	Build confidence and gain new skills to make accurate measurements, with flexible Education Services developed by Keysight experts. Including Start-up Assistance.
Alternative acquisition options	
KeysightAccess	Reduce budget challenges with a subscription service enabling you to get the instruments, software, and technical support you want for your test needs.

Recommended services

Maximize your test system up-time by securing technical support, repair, and calibration services with committed response and turnaround times. 1-year KeysightCare Assured is included in every new instrument purchase. Obtain multi-year KeysightCare upfront to eliminate the need for lengthy and tedious paperwork and yearly requests for maintenance budget. Plus, you benefit from secured service for 2, 3, or 5 years.

Keysight Services

Service	Function
KeysightCare Enhanced¹	Includes tech support, warranty and calibration
R-55B-001-1	KeysightCare Enhanced – Upgrade 1 year
R-55B-001-2	KeysightCare Enhanced – Extend to 2 years
R-55B-001-3	KeysightCare Enhanced – Extend to 3 years (Recommended)
R-55B-001-5	KeysightCare Enhanced – Extend to 5 years (Recommended)
KeysightCare Assured	Includes tech support and warranty
R-55A-001-2	KeysightCare Assured – Extend to 3 years
R-55A-001-3	KeysightCare Assured – Extend to 3 years
R-55A-001-5	KeysightCare Assured – Extend to 5 years
Start-Up Assistance	
PS-S40-01 or -04	Instrument fundamentals and operations starter
PS-S40-02	Optional – technology and measurement science standard learning

1. Available in select countries. For details, please view the datasheet. R-55B-001-2/3/5 must be ordered with R-55B-001-1.



Keysight enables innovators to push the boundaries of engineering by quickly solving design, emulation, and test challenges to create the best product experiences. Start your innovation journey at www.keysight.com

This information is subject to change without notice. © Keysight Technologies, 2018 – 2024, Published in USA, October 1, 2024, 5992-1620EN