

LCR Meter

6630

Features

- Frequency range: DC, 10Hz to 1/3/5/10/20/30/50MHz
- Basic accuracy up to $\pm 0.08\%$ (typical $\pm 0.05\%$)
- ALC function
- Output impedance 25 Ω /100 Ω , switchable
- Support meter mode and list mode, can used with various fixtures, such as: liquid dielectric material test fixture, dielectric material test fixture and magnetic material test fixture
- Ultra-high measuring speed < 3ms
- Open circuit/short circuit/load correction function
- Up to four component parameters can be selected in the electric meter mode. The inductance and DCR values can be measured and displayed simultaneously
- Auto component classification: Comparator function and Handler BIN classification function
- Support RS-232, GPIB, Handler, LAN, USB Host/Device interfaces
- PC connection data analysis software is available



CE RS-232 LAN USB Host/Device GPIB Handler

Applications

- Passive Components: Capacitor, Inductor, Resistor, Transformer, Ceramic resonator, Quartz Crystal
- Semiconductor Components: The CV characteristics analysis of varactor diodes, Diodes
- Dielectric Material: Estimation on permittivity and consumption tangent of plastic, ceramic and PCB
- Other Components: Estimation of the impedance of PCB components

Accessories / Fixtures

Standard Accessories

- Power Cord
- DIP Test Fixture (FX-000C19)



Optional Accessories

- PC Link software



- F423906A Kelvin Clip Leads (with BNC Box)



- F423503 DIP Test Fixture



- F423504 DIP Test Fixture



- FX-000C6 DIP Test Fixture



- F423905 SMD Test Fixture



- FX-000C10 Bottom Electrode SMD Test Fixture

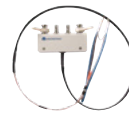

- FX-000C11 SMD Tweezer Test Leads



- FX-000C12 SMD Test Fixture Leads



- FX-000C7 Dielectric Material Test Fixture



- FX-000C8 Magnetic Material Test Fixture



- F663001 A/B/C BNC Test Leads



- FX-000C9 Material Testing Fixture

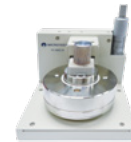

- FX-000C20 Liquid Dielectric Material Test Fixture



- F420001 External Voltage Bias ($\pm 200V/1MHz$)



- F420003 External Voltage Bias ($\pm 40V/1MHz$)



- F420005 External Voltage/Current Bias ($\pm 40V/100mA$)



- F420006 External Voltage Bias ($\pm 2000V/1MHz$)



- FX-LR0001 Automatic Level Compensation Fixture

Specifications

Model Name	6630-1	6630-3	6630-5	6630-10	6630-20	6630-30	6630-50
Test Frequency	10Hz-1MHz	10Hz-3MHz	10Hz-5MHz	10Hz-10MHz	10Hz-20MHz	10Hz-30MHz	10Hz-50MHz
Frequency Resolution	100mHz, 6-bit Frequency Input						
Frequency Output Accuracy	±0.01%						
Basic Accuracy	±0.05%						
AC Drive Level	Test Signal Voltage Level	10mV-2Vrms					
	Voltage Minimum Resolution	1mV					
	Accuracy	ALC OFF: 10%* Voltage ±2mV ALC ON: 6%* Voltage ±2mV					
	Test Signal Current Level	200μA-20mArms					
	Current Minimum Resolution	10μA					
	Accuracy	ALC OFF: 10%* Current ±20μA ALC ON: 6%* Current ±20μA					
DC Drive Level	1V (fixed)						
Output Impedance	25Ω, 100Ω (switchable)						
Test Time (Fastest)	<3mS						
Measurement Parameters and Ranges	Z	0.000mΩ-9999.99MΩ					
	R, X	±0.000mΩ-9999.99MΩ					
	Y	0.00000μS-999.999kS					
	G, B	±0.00000μS-999.999kS					
	θRAD	±0.00000-3.14159					
	θDEG	±0.000°-180.000°					
	Cs, Cp	±0.00000pF-9999.99F					
	Ls, Lp	±0.00nH-9999.99kH					
	D	0.00000-9999.99					
	Q	0.00-9999.99					
	Δ	±0.00%-9999.99%					
	Rdc	0.00mΩ-99.9999MΩ					
	ε' ε''	0-100000					
	μr' μr''	0-100000					

General

Measurement Mode	Meter mode, list mode
Measurement Circuit	Series/Parallel
Correction	Open Circuit/Short Circuit/Load correction
Cable Compensation	0/ 0.5/ 1/ 2 m
List Mode	50 groups of Multi-steps setting (Each group contains up to 15 steps)
BIN	9
Comparator	ABS, ΔABS, Δ%, OFF
Built-in Storage	100 sets LCR Meter setting documents, 50 sets list mode setting documents
USB Host Storage	LCR setting documents, list mode setting documents, BMP graphics
Trigger Test	Auto, Manual, RS-232, GPIB, Handler
Interface	RS-232, GPIB, Handler, LAN, USB Host/Device
Power Supply	Voltage 100-240Vac
	Frequency 50-60Hz
	Low power consumption: Maximum 30W (Nominal value)
Power Consumption	30VA
Display	7.0" TFT, 800×480 color screen
Environment	Temperature: 10°C-40°C, Humidity: 20-80%RH
Dimension (W*H*D)	336×147×340mm
Weight	3kg

6630 Key Features

A Function Introduction



Four Parameters Displayed Simultaneously
7.0" TFT, 800×480 color screen, and four parameters can be displayed simultaneously.



Correction

Before measuring the DUT, you should select "Correction" button to do open, short, and HF Load or SPOT Load correction.

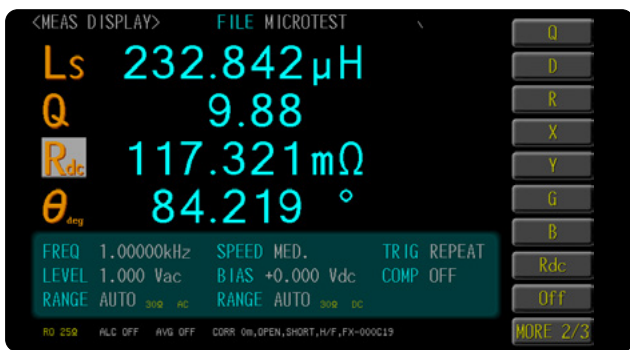

Measure Inductor (DCR)

Inductor coil turns and winding materials will affect DCR value. The key parameters for inductor are Ls / Lp / Q / SRF / DCR.



List Mode

50 groups of list mode setting (Each group contains up to 15 steps).

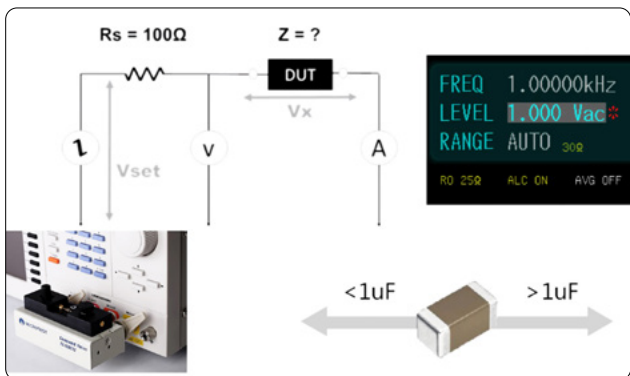

Output Impedance 25Ω/100Ω and Auto Level Control (ALC)

The key parameters for capacitance are Cs/Cp/D/Q/ESR/DC Bias Voltage.

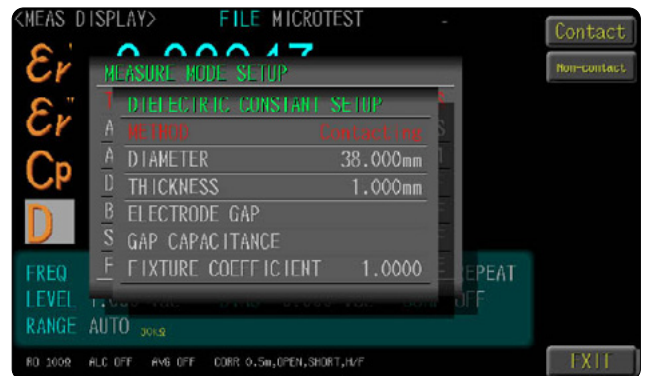

Dielectric Material Test Fixture (FX-000C7)

Using the dielectric material test fixture for measuring PCB board or ceramic board. 6630 built-in formula to directly calculate the material dielectric value ϵ_r' , ϵ_r'' .



Liquid Dielectric Material Test Fixture (FX-000C20)

Using the liquid dielectric material test fixture for measuring the characteristics of electrochemical materials.



Magnetic Material Test Fixture (FX-0000C8)

Using the magnetic material test fixture for measuring of permeability of various toroidal cores or ferrite cores and electromagnetic shielding coating materials, 6630 built-in formula to directly calculate the permeability coefficient value μ' , μ'' .

B High productivity

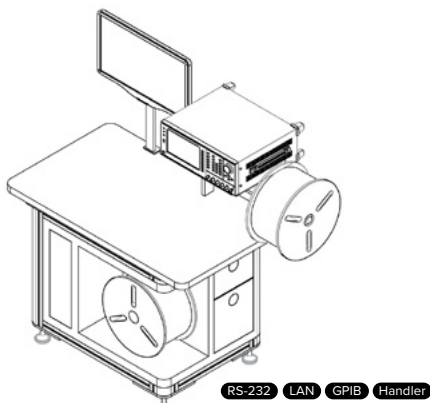

Automatic Production Line

Connect 6630 RS-232, LAN, GPIB or Handler to automatic machine (measuring speed < 3mS).

C Applications

Passive Component



inductance
Ls / Lp / Q / SRF / I sat / I rms

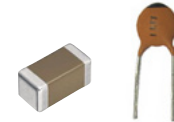

MLCC/capacitance
Cs / Cp / D / Q / ESR / DC Bias Voltage

Acoustic Components



Voice coil motor/Hearing aids
Ls / Q / Qm / SRF

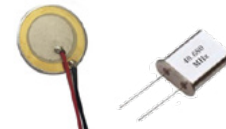

Piezoelectric element / quartz crystal
Cs / Cp / D / Fs / Fp

Material



Magnetic material
 μ' μ''

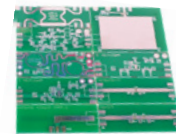

Dielectric/ceramics / Electrochemical materials
 ϵ' ϵ''

Wireless RF / Power Supply



Wireless charging
Ls / Q / SRF / DCR / Rs



NFC/low Freq. RFID
Ls / Q / SRF / DCR / Rs



battery
ESR / Cs / Cp / D

Semiconductor Components

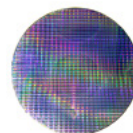

Wafer
C-V



LED Light board
Z / Cs / Cp / D



diode
Cs / Cp / D